

**Edge-Of-Dock Curb Details**

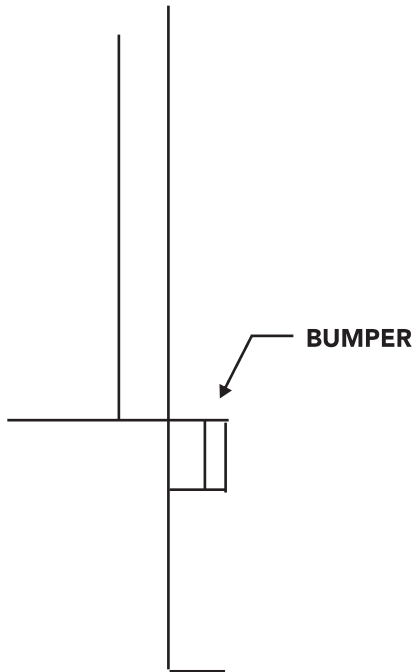

**SECTION**

**ISOMETRIC VIEW**

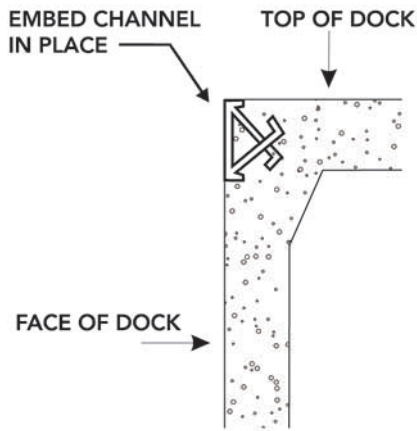
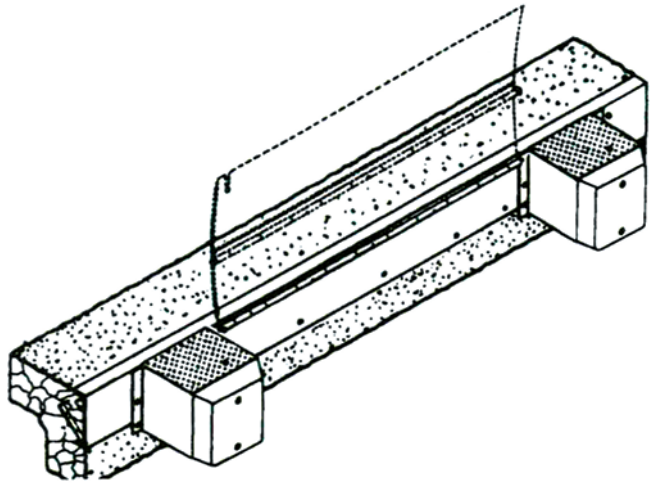

**E.O.D. 8" MIN. STRUCTURAL CHANNEL DETAIL**

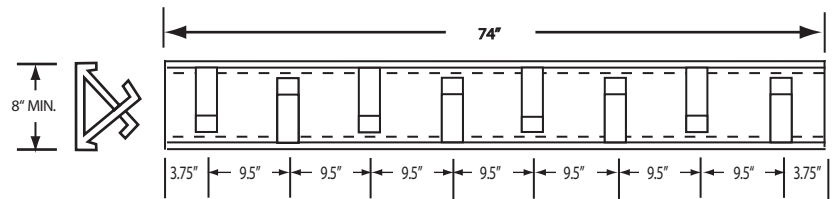

8" STRUCTURAL CHANNEL  
11.5 LB. FT  
.22" WEB THICKNESS  
2.26" FLANGE WIDTH

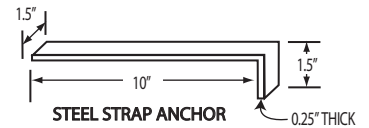

**NOTE: DRAWINGS NOT TO SCALE**

Customer: \_\_\_\_\_  
 Signature Approval By: \_\_\_\_\_  
 Project: \_\_\_\_\_  
 Address: \_\_\_\_\_  
 City: \_\_\_\_\_ State: \_\_\_\_\_  
 Architect/GC: \_\_\_\_\_

*Authorized Dealer*

Consistent with our policy of continuing product improvement, we reserve the right to change these specifications without notice or obligation.